



UWWT

LEVEL. UP TO THE MAX.

6 YEARS
GUARANTEE
APPROVED
QUALITY

**LEVEL MEASUREMENT
AT THE HIGHEST LEVEL**

A professional photograph of three men standing side-by-side against a blue gradient background. The man on the left is wearing a dark navy suit, the man in the center is wearing a grey suit, and the man on the right is wearing a dark navy suit. All three are smiling and have their hands in their pockets. The text 'TECHNOLOGY. PERFORMANCE. PARTNERSHIP.' is overlaid in white, bold, uppercase letters across the middle of the image.

TECHNOLOGY. PERFORMANCE. PARTNERSHIP.

LEVEL. UP TO THE MAX.

UWT GmbH in Betzigau is the expert in level measurement technology and a reliable, world leading solution provider for the safe and accurate detection of levels and limit levels in silos and material processing across a wide variety of industries. Whether for bulk goods, liquids, pastes or foams - UWT, with product lines such as Rotonivo®, Vibranivo® and NivoBob®, is synonymous with the perfect measurement technology solution for almost every application.

With production sites in Betzigau and in Malta, as well as further locations in the USA, Great Britain, Spain, Poland, China, India, Brazil and Mexico, several million applications have now been put into practice worldwide. UWT stands for level measurement technology at the highest global standards. The whole enterprise is based on the three strong pillars of technology, performance and partnership together with collaboration at eye level - with customers, suppliers, partners and close to 200 employees. We have carved out an outstanding and strategic position in the market within the area of limit levels for bulk solids, and set new standards with the rotary paddle switch. In addition, we offer end-to-end digitisation: from the latest E-tools, which enable quick

and easy product selection, configuration and commissioning, through easy and intuitive operation to innovative device communication, all of which ensure smooth operation. The high quality and reliability of the UWT products, the robust design, the easy handling and the longevity of the sensors ensure low down-times, high levels of system availability and thus a high degree of operational security. All made in Germany. The range of products and services has been continuously developed and now also includes monitoring and visualisation systems as well as complete system configuration. Further proof of how unswervingly UWT GmbH is geared towards growth.

As an owner-managed, German, medium-sized company, UWT is ideally positioned with an international sales network in over 90 countries with personal contacts on site, available locally. Open and honest communication with customers and partners alike characterise UWT together with its loyal and satisfied employees. The notable great team spirit ensures that UWT feels like one big family – and that's what counts.

MISSION STATEMENT

Social commitment and social responsibility are essential components of the corporate philosophy at UWT. The focus is on sport, culture and social issues. Environmental protection and responsibility for the future are also very important at UWT. The provision of e-charging stations, durable, resource-

saving products and the use of green electricity underlines this. So it's no wonder that UWT is one of "Germany's Best Employers", is a "Great Place to Work®" and is one of the winning companies in "Best Employers in the Allgäu".

OUR CLIENTS

AZO | ZEPPELIN | TESLA | BASF | NESTLÉ | HOLCIM | SIEMENS | BECK'S | VW
PLAYMOBIL | HENKEL | UNILEVER | HEIDELBERGER ZEMENT | LAFARGE | LIEBHERR

*

*and many more

QUALITY CERTIFICATES



APPROVALS WORLDWIDE



THE LEVEL COMPANY

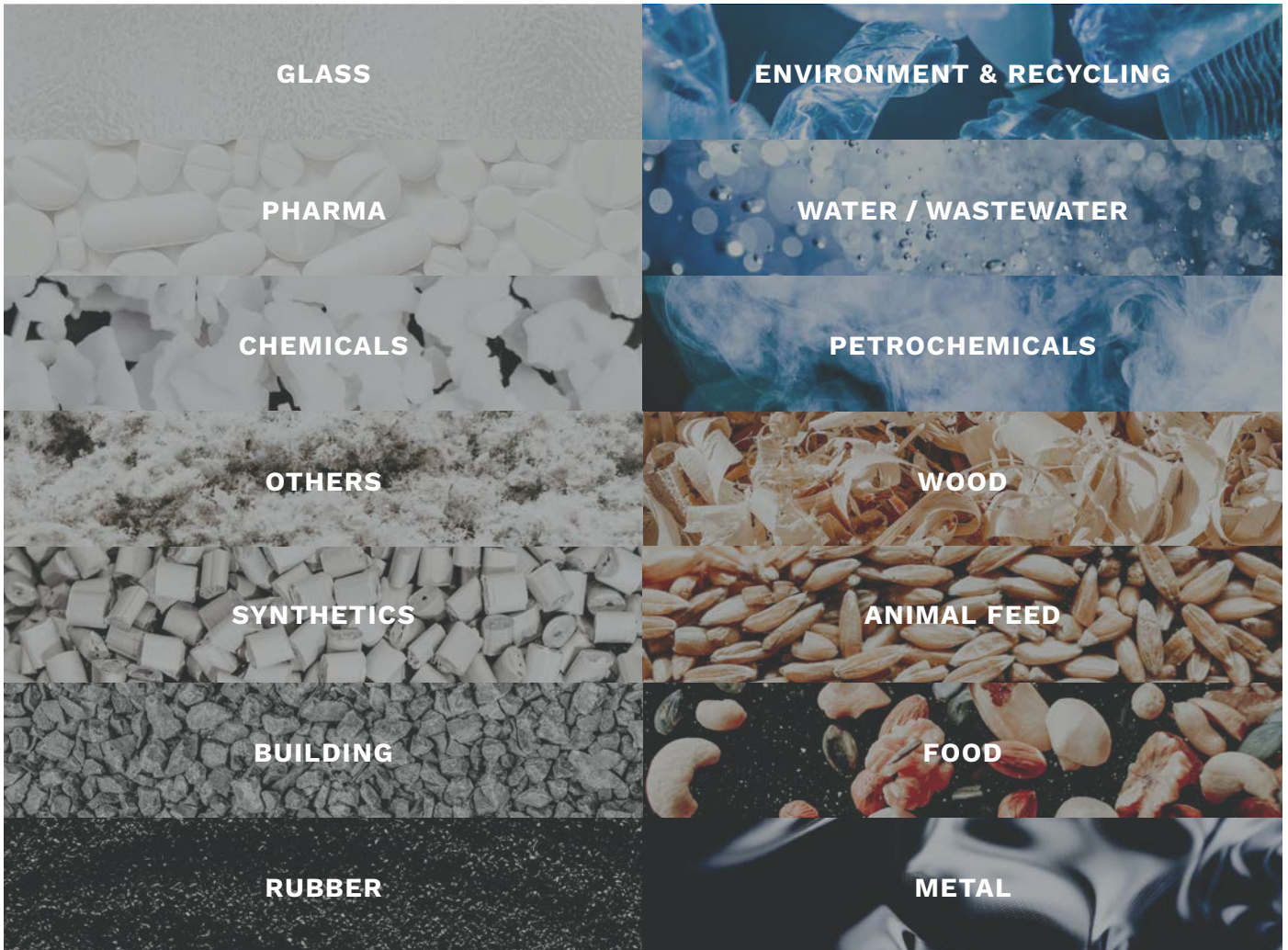

SOLIDS

UWT is a recognised expert for level measurement of any bulk material in a wide variety of industries and offers solutions across a vast range of applications, including specialist solutions.



LIQUIDS

UWT offers a wide range of products for liquids with highly reliable solutions for level and point level measurement.

An aerial photograph of a large industrial facility, likely a water treatment plant. The image is dominated by several large, circular, ribbed structures, possibly clarifiers or aeration tanks, arranged in a grid-like pattern. The structures are light-colored with dark ribs. In the background, there are various industrial buildings, walkways, and a red structure. The overall scene is industrial and complex.

PERFORMANCE. UP TO THE MAX.

WEBSHOP



24/7 ONLINE WEBSHOP

Product Information & Downloads available around the clock.

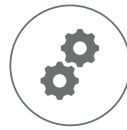

PRODUCT CONFIGURATION

Configure products with just a few clicks. Save, edit & share your configurations.



FAST TRACK PRODUCT FINDER

Step-by-step to the right sensor for your application.



PRICE INFORMATION

Prices are shown according to user role or you can request a quote.



PRODUCT COMPARISON

Compare the main features of your chosen products.



FAVOURITES LIST

Save your favourites and create individual lists with your configurations.



CASE STUDIES

From a variety of applications and industries.



APPLICATION DATABASE

Search for specific examples of level measurement installations from around the world.



Rotonivo®



ROTARY PADDLE LEVEL SWITCH FOR SOLIDS

A motor driven shaft causes a vane to rotate. Once the material level reaches the vane, thereby preventing further rotation, switches are activated which result in an output signal and the motor stops. When the vane is free again from material, the output signal is reset and the motor driven shaft rotates again.

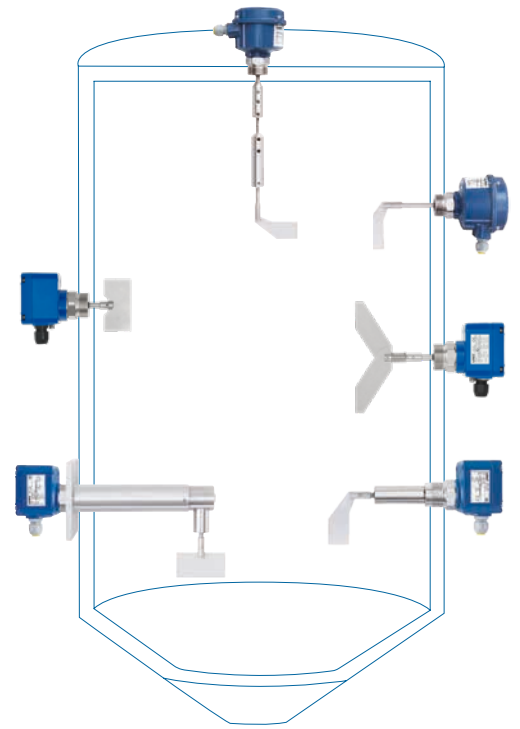

RN 3001



RN 3002 Rope



RN 3002 Tube



RN 6002 reinforced rope



RN 6003



RN 6004



SPECIAL FEATURES:

- Universal voltage electronics
- Adjustable sensitivity (≥ 15 g/l)
- Rotation principle unaffected by caking
- Robust aluminum die-cast housing
- Protected motor (friction clutch, double bearing)
- Tube and metal rope extension
- Different rotary paddles for special solutions
- Temperature range -40 °C to $+1,100$ °C
- High quality grade stainless steel (process)
- RN 6000 is world's first rotating level limit switch compliant to SIL 2

OUR SOLUTIONS FOR:

- Strong caking
- Dusty environments
- Abrasive materials
- Over pressure and low pressure environments
- Heavy mechanical loading
- Electrostatic charging
- Variable parameters
- Explosive environments
- Hygienic applications

Rotonivo®



ROTARY PADDLE LEVEL SWITCH FOR SOLIDS

A motor driven shaft causes a vane to rotate. Once the material level reaches the vane, thereby preventing further rotation, switches are activated which result in an output signal and the motor stops. When the vane is free again from material, the output signal is reset and the motor driven shaft rotates again.

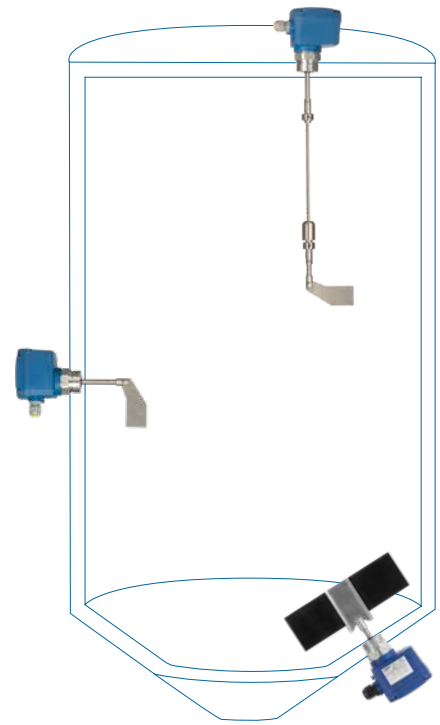

RN 4001



RN 4001
Oscillating
shaft



RN 4001
Rope



SPECIAL FEATURES:

- Cost-effective design
- Universal voltage electronics (without microswitch)
- Adjustable sensitivity (≥ 35 g/l)
- Rotation principle unaffected by caking
- Plastic housing with dust-Ex approval
- Protected motor (friction clutch, double bearing)
- Version with pendulum shaft or cable extension

OUR SOLUTIONS FOR:

- Strong caking
- Dusty environments
- Over pressure and low pressure environments
- Heavy mechanical loading
- Explosive environments
- Variable parameters

Vibranivo®



VIBRATING FORK LEVEL SWITCH FOR SOLIDS & SEDIMENTS IN LIQUIDS

Electronically stimulated piezos cause the fork to vibrate. As soon as the sensor is covered with material, the vibration is dampened and the resulting electrical current change causes the output signal to switch. Once the material level falls below the sensor it is free to vibrate again and the output signal is reset.

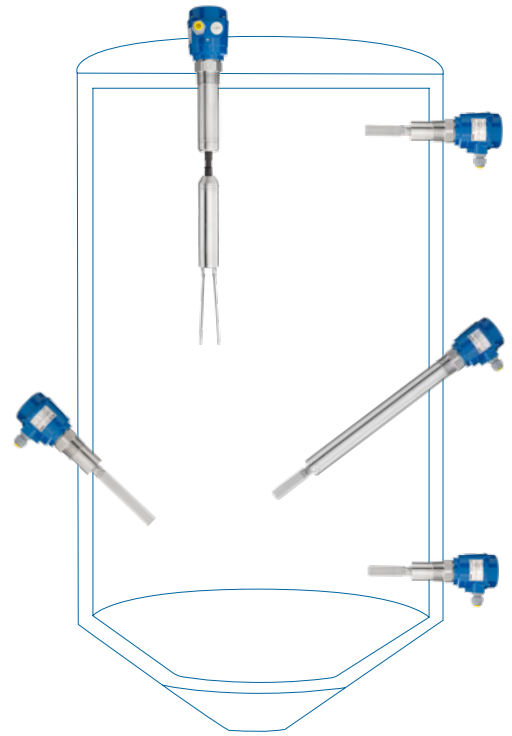

VN 1020



VN 2030



VN 5040



VN 6050



Remote
Version



SPECIAL FEATURES:

- 2-wire technology
- Very high sensitivity (< 5 g/l - Vibrasil®)
- Surface roughness 0.75 µm
- High quality material (SS 316L)
- Suitable for overpressure up to 16 bar
- Temperature range -40 °C to +150 °C
- Extremely robust version
- PFA coating
- NAMUR Standard
- Universal voltage electronics

OUR SOLUTIONS FOR:

- Extremely light product density
- Pneumatic filling
- Applications with process overpressure
- Limited space
- Vibration within the vessel
- High reliability requirements
- High hygienic requirements
- Sediment levels in liquids

Vibranivo®



VIBRATING FORK LEVEL SWITCH FOR SOLIDS

The vibrating fork is set into vibration by piezo elements. The vibration is stopped by the surrounding bulk material. The resulting change in voltage within the piezo elements is electronically detected, triggering a switch output.

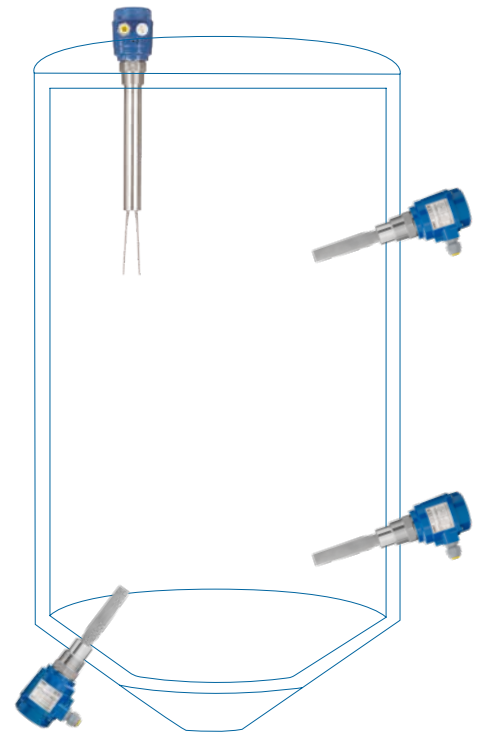

VN 4020



VN 4030



VN 4040



SPECIAL FEATURES:

- Cost-effective design
- Very high sensitivity (> 30 g/l)
- High-quality process materials
- Suitable for overpressure up to 16 bar
- Temperature range -40 °C to +150 °C
- Extremely robust version
- Universal voltage electronics

OUR SOLUTIONS FOR:

- Pneumatic filling
- Applications with process overpressure
- Limited space
- Vibration within the vessel
- High reliability requirements

Vibranivo®

VIBRATING FORK LEVEL SWITCH FOR LIQUIDS

The vibrating fork is set into vibration at its resonant frequency by piezo elements. When the fork tines come into contact with liquids, the frequency changes. This frequency change is electronically detected, and a switch output is activated.

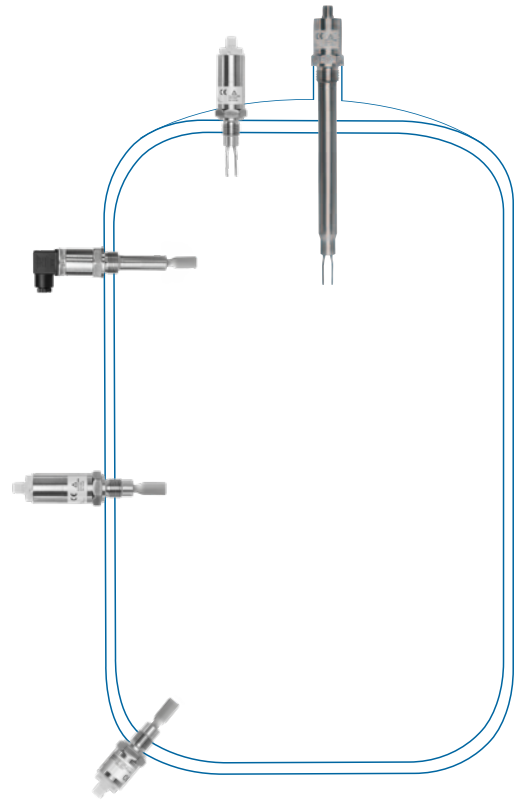

VN 7120
100°



VN 7120
150°



VN 7120
Extension



VN 7120
Valve plug



VN 7130
100°



VN 7130
150°



SPECIAL FEATURES:

- Insensitive to material build-up, flows, turbulence and air bubbles
- Ultra-compact design with ½" process connection
- Uniquely bright signal LED, selectable colours
- IO-Link communication
- Hygienic design, hygienic adapter
- CIP / SIP compatible
- Pipe extension up to 4 m
- Complete stainless steel design (IP 69K / Type 6P)
- Potted electronics

OUR SOLUTIONS FOR:

- Limited space
- Hygienic applications
- High-viscosity liquids
- Agitator tank
- Pressure vessel
- Leakage monitoring
- Fast commissioning without material synchronisation

Mononivo®



VIBRATING ROD LEVEL SWITCH FOR SOLIDS

Electronically stimulated piezos cause the single rod probe to vibrate. When the material covers the sensor, this causes the vibration to stop and a voltage change is caused within the piezo elements. This is electronically registered and causes the output signal to switch.

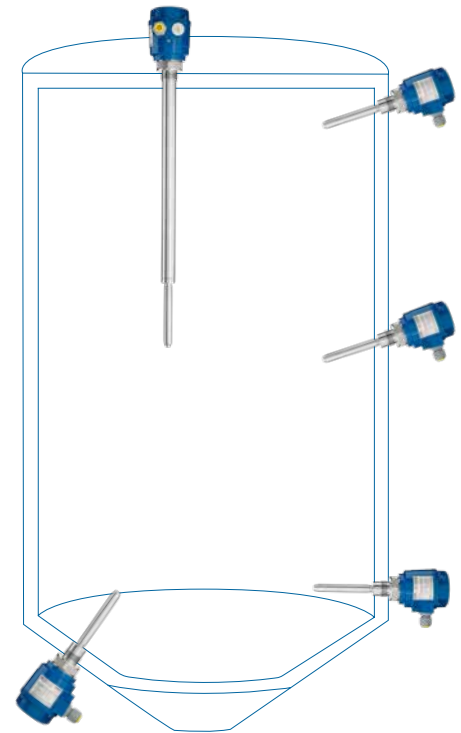

MN 4020



MN 4030 Tube



MN 4040 Tube screwed



SPECIAL FEATURES:

- Compact limit switch with threads from 1"
- Sensitivity adjustable in 4 settings
- High surface quality
- High quality material (SS 316L)
- Heavy mechanical loading
- Robust version for overpressure up to 16 bar
- Temperature range -40 °C to +150 °C
- Backflow detection in pipes and shafts

OUR SOLUTIONS FOR:

- Light products from 20 g/l
- Powdery material with strong caking properties
- Coarse-grained granulate
- Process overpressure
- Limited space
- Vibration within the vessel
- High safety standard
- High hygienic requirements
- Explosive environments

RFnivo®

CAPACITANCE LEVEL SWITCH FOR SOLIDS

The capacitive level limit switch is automatically calibrated to a reference capacitance of an empty vessel. If the probe is covered by the product, the measured capacitance changes through the dielectric and a switching signal is activated. The integrated "Active Shield" technology ensures high reliability even for products that cause caking.

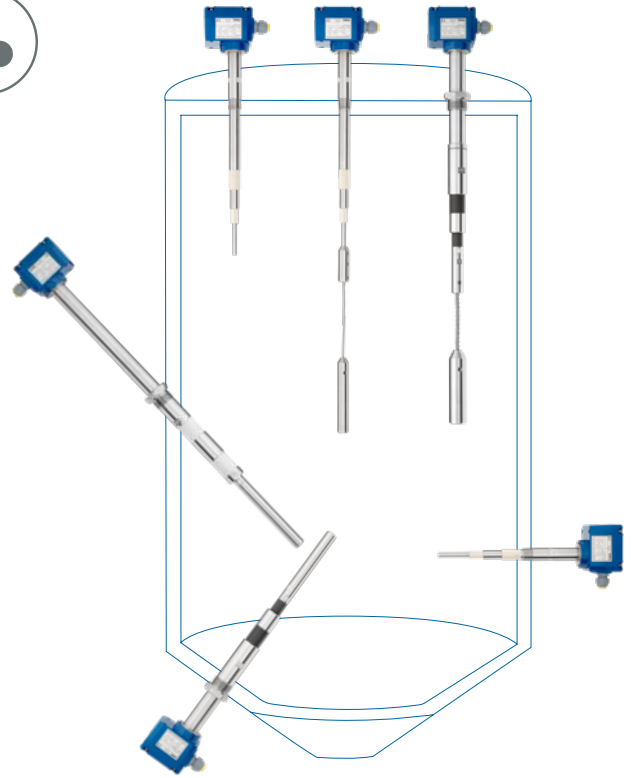

RF 3100



RF 3200



RF 3300 Temp.



Remote Version



SPECIAL FEATURES:

- Very high sensitivity ($DK \geq 1.5$)
- High mechanical load
- High quality process materials (SS 316L, ceramics, PPS)
- Robust version for overpressure up to 25 bar
- Temperature range -40 °C up to $+500\text{ °C}$
- RF 3100 PROTECTION PLUS version with anti-corrosive PFA coating

OUR SOLUTIONS FOR:

- Heavy materials
- Dusty environments
- Abrasive and aggressive media
- Positive and negative pressure
- Caking material
- Vibration in the vessel
- Hazardous areas
- EHEDG applications

RFnivo®

CAPACITANCE LEVEL SWITCH FOR LIQUIDS & INTERFACE

The capacitive measuring limit switch responds to the change in capacitance at the probe, which is detected by the change in the oscillating frequency. The integrated “Active Shield” technology ensures high reliability even for products that cause caking.

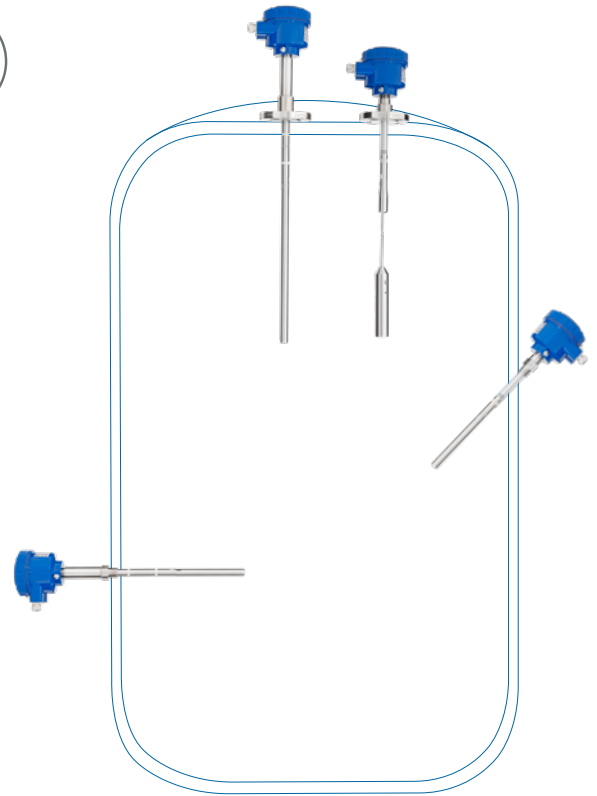

RF 8100 Rod



RF 8100 Rope



RF 8200 Temp.



SPECIAL FEATURES:

- Functionality independent of silo wall
- Temperature range -40 °C up to + 400 °C
- Robust version for overpressure up to 35 bar
- Digital electronics with Profibus PA, integrated display and operating menu (optional)
- Potted electronics
- Very high sensitivity ($DK \geq 1.5$)
- Rod and metal rope extension (up to 25 m)
- WHG certification
- Certification accord. Lloyd's Register

OUR SOLUTIONS FOR:

- All types of liquids
- Applications with condensation
- Very strong caking
- Aggressive materials
- Vibrations within the process
- High safety standard
- Explosive environments
- Interface measurement

Capanivo®



CAPACITANCE LEVEL SWITCH FOR SOLIDS

The electrodes in the sensor form a capacitor. When the sensor is touched by the product, the capacitance changes, and the electronics convert this into a switching signal. The integrated “Active Shield” technology allows this system to be used in particularly adhesive materials.

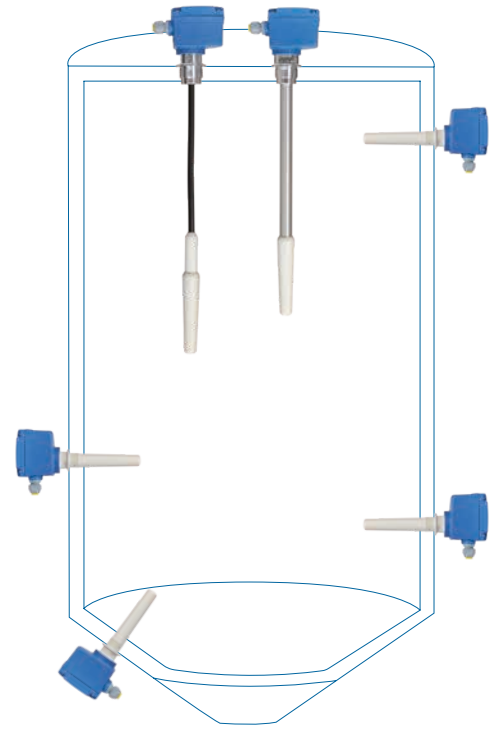

CN 4020



CN 4020 Temp.



CN 4030 Tube



CN 4050 Cable



SPECIAL FEATURES:

- Suitable for use in non-metallic containers
- Very high sensitivity ($DK \geq 1.6$)
- Functionality independent of silo wall
- Versatile supply voltages
- Adjustable switching delay
- Tube and cable extension
- Overpressure up to 25 bar
- Temperature range -40 °C to $+180\text{ °C}$
- Food compliant version

OUR SOLUTIONS FOR:

- Light materials
- Dusty environments
- Pneumatic filling
- Very strong caking
- Aggressive material
- High safety standard
- Explosive environments

Capanivo®



CAPACITANCE LEVEL SWITCH FOR LIQUIDS & INTERFACE

The electrodes in the sensor form a capacitor. If the product comes into contact with the sensor, the capacitance changes and the electronics converts it into a switching signal. Available as version with stainless steel or synthetic housing. The integrated “Tip Sensitivity” and “Active Shield” technology guarantee a high level of functional reliability even for products that cause caking.

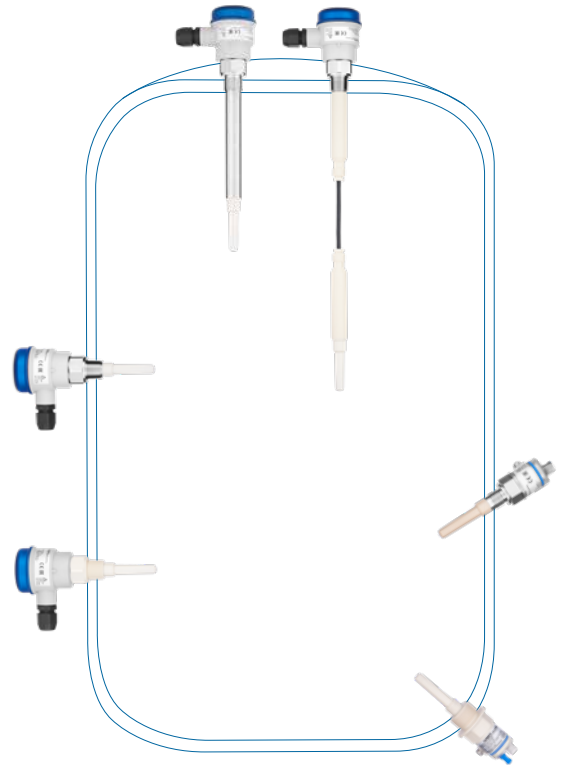

CN 7120



CN 7121



CN 7130 Tube



CN 7150 Cable



SPECIAL FEATURES:

- Available with two different housing sizes
- Compact limit switch from ½" connection thread
- Installation in all tank types and shapes
- For use in metallic and non-metallic containers
- Very high sensitivity ($DK \geq 1.5$)
- Temperature range -40 °C up to $+125\text{ °C}$ (CIP suitable up to 150 °C)
- IO-Link with PNP, NPN, push pull signal output
- 8/16 mA or 4...20 mA continuous current output
- WHG and VLAREM certification

OUR SOLUTIONS FOR:

- All types of liquids
- Strong caking
- Limited space
- Aggressive materials
- High safety standard
- High hygiene requirements
- Explosive environments
- Leakage detection
- Interface measurement

Capanivo®



CAPACITANCE LEVEL SWITCH FOR LIQUIDS & INTERFACE

The electrodes in the sensor form a capacitor. If the product comes into contact with the sensor, the capacitance changes and the electronics converts it into a switching signal. The integrated “Tip Sensitivity” technology guarantees a high level of functional reliability even for products that cause caking.

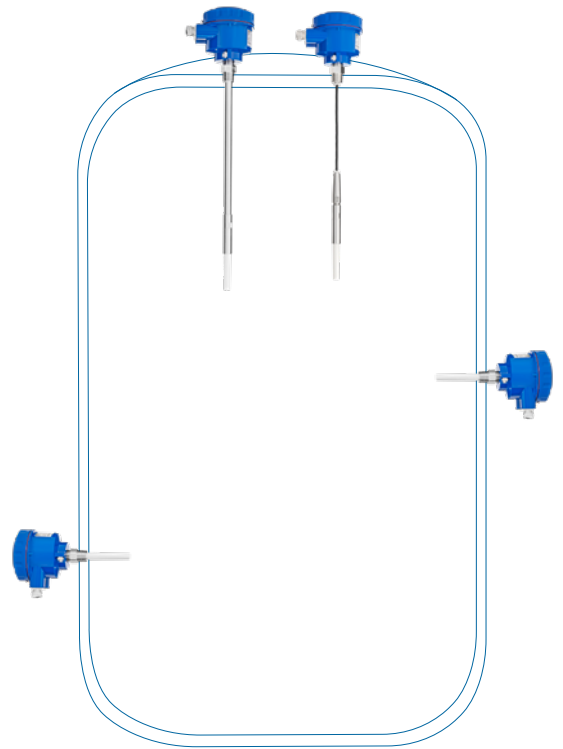

CN 8100



CN 8100 Tube



CN 8100 Cable



Remote Version



SPECIAL FEATURES:

- For use in metallic and non-metallic containers
- Very high sensitivity ($DK \geq 1.5$)
- Potted electronics
- Digital electronics with Profibus PA, integrated display and operating menu (optional)
- Robust version for overpressure up to 25 bar
- Temperature range -40 °C up to $+125\text{ °C}$
- WHG certification
- Certification accord. Lloyd's Register
- SensGuard cover (optional)

OUR SOLUTIONS FOR:

- All types of liquids
- Measurement range of up to 30 m
- Strong caking
- Vibrations within the process
- Aggressive materials
- High safety standard
- Explosive environments
- Leakage detection
- Interface measurement

NivoCapa®



CAPACITANCE LEVEL TRANSMITTER FOR LIQUIDS & INTERFACE

The sensor measures the electrical capacitance of the product, which is proportional to the fill level in the container. The integrated “Active Shield” technology allows this system to be used in particularly adhesive materials.

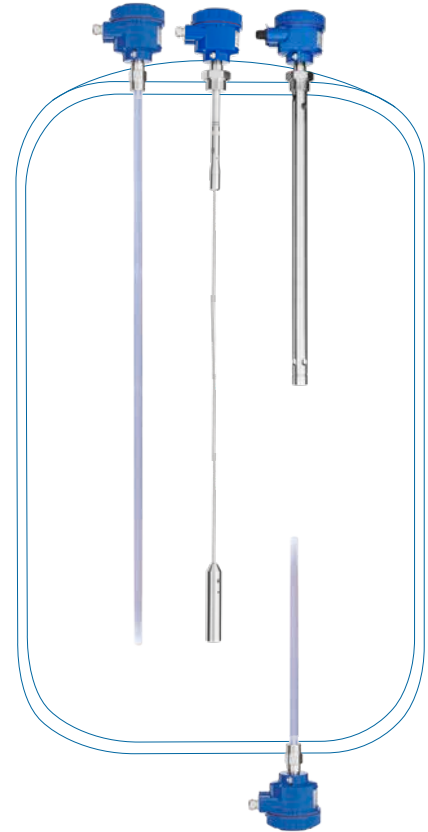

NC 8100 Rod

NC 8100 Coax

NC 8100 Rope



SPECIAL FEATURES:

- For use in metallic and non-metallic containers
- 2-wire technology (output signal 4...20 mA according to NAMUR NE 43)
- Very high sensitivity ($DK \geq 1.5$)
- Rod and metal rope extension (up to 25 m)
- Robust version for overpressure up to 35 bar
- Temperature range -40 °C up to $+200\text{ °C}$
- Quick response time
- PFA coating
- Programmable electronics with buttons
- Certification accord. Lloyd's Register

OUR SOLUTIONS FOR:

- All types of liquids
- Condensation
- Very strong caking
- Aggressive materials
- High safety standard
- Explosive environments

NivoBob®

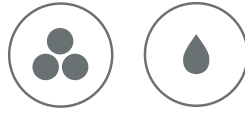

ELECTROMECHANICAL PLUMB BOB FOR SOLIDS & LIQUIDS & SEDIMENTS IN LIQUIDS

A sensor weight attached to either a metal tape or rope is electromechanically lowered into the vessel. Once the sensor weight rests on the material, the winding direction of the motor changes and the sensor weight is rewound to the upper stop position. As the weight is lowered, the distance is electronically measured. Microprocessors convert the measured distance together with the programmed silo geometry into a volumetric output signal. This signal is updated each time the sensor weight is lowered.

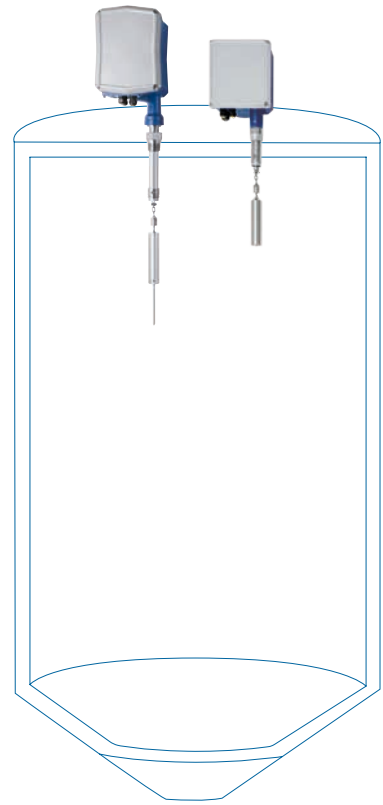

NB 3100



NB 3200



NB 3300



NB 3400



NB 4100
Aiming flange



NB 4200



SPECIAL FEATURES:

- High sensitivity (≥ 20 g/l)
- Various sensor weights
- Rope and tape version
- Overpressure version up to 1.7 bar
- Temperature range -40 °C to $+250$ °C
- Service life up to 500,000 cycles of tape version
- Integrated tape cleaner
- Diagnostics function
- Comm. via Modbus RTU or Profibus DP

OUR SOLUTIONS FOR:

- Strong caking
- Material with changing temperature / humidity
- Measurement range of up to 50 m
- Electrostatic charging
- Heavy and very light materials
- Limited space
- Low dielectric constant
- Dusty environments



TECHNOLOGY. UP TO THE MAX.

NivoRadar®



RADAR SENSOR FOR SOLIDS

A high-frequency 80 GHz signal is transmitted with a very narrow beam angle. The signal is reflected by the bulk material and received back to the sensor. The frequency difference, which is directly proportional to the distance, is then further processed and output as the level signal. The narrow beam angle makes the use in narrow, tall silos possible and facilitates the installation and alignment of the sensor.

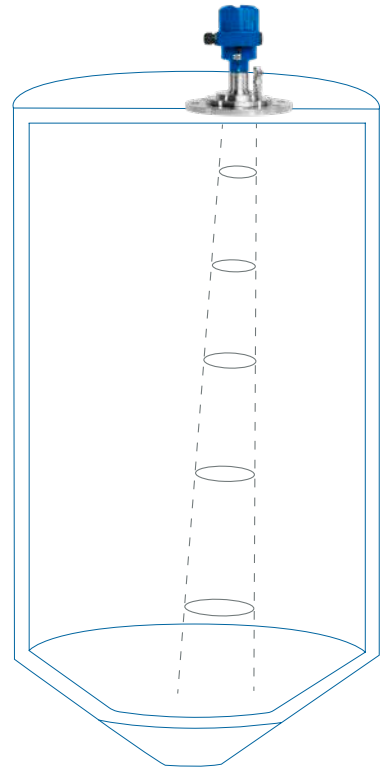

NR 3100
Plastic horn
antenna



NR 3200
Threaded
antenna



NR 3300
Lens antenna



NR 3300
High-temperature
standpipe



UWT LevelApp

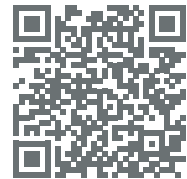

Google Play



App Store

SPECIAL FEATURES:

- Very high sensitivity
- 80 GHz technology
- 3° narrow beam angle
- Flush-mounted lens antenna
- Integrated lens cleaner
- Adjustable flange design up to max. 10°
- Temperature solutions -55 °C up to +250 °C
- Process temperature up to 1,200 °C with standpipe
- Compact version with 1 ½" threaded connection
- Quick Start Wizard
- Configuration via UWT LevelApp
- Various electronics versions: 4..20 mA, HART, Modbus

OUR SOLUTIONS FOR:

- Very light bulk materials
- Dusty environment
- Use within tall, narrow silos up to 120 m
- Optimum reflections of bulk material with material cone
- Aggressive material
- Perfect positioning
- Explosive environments

NivoRadar®



RADAR SENSOR FOR LIQUIDS

A high-frequency 80 GHz signal is transmitted with a very narrow beam angle and a two-wire technology. The signal is reflected by the medium and received back to the sensor. The frequency difference, which is directly proportional to the distance, is then further processed and output as a level signal. The sensor is ideal for use in process tanks and is also suitable for acids and alkalis. Measurement through the top of plastic tanks is possible without any problems.

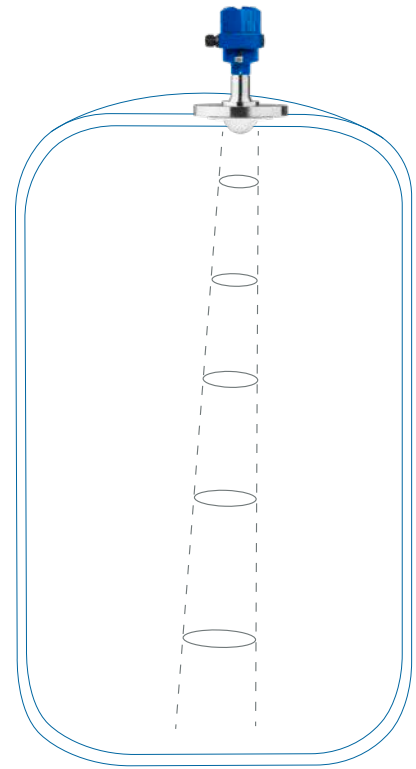

NR 8100
Plastic horn
antenna



NR 8200
Threaded
antenna



NR 8300
PTFE-
encapsulated
antenna



NR 8400
Hygienic
antenna



NR 8500
High-temperature
version



SPECIAL FEATURES:

- Very compact with a 3/4" process connection
- PTFE-encapsulated version
- Measurement up to the antenna tip (minimal blocking distance)
- Very high sensitivity
- 80 GHz technology
- 3° narrow beam angle
- Potted electronics, Protection class IP66 / IP68, Type 6P
- Temperature solutions -196 °C to +450 °C
- Quick Start Wizard, Configuration via UWT LevelApp
- Pressure-resistant design (Ex d)
- CIP / SIP compatible

OUR SOLUTIONS FOR:

- Liquids of all kinds
- Very strong caking
- Steam, outgassing and condensation
- Optimal reflection of moving surfaces
- Aggressive materials
- Potentially explosive areas
- Individual positioning of the sensor

NivoRadar®



RADAR SENSOR FOR SOLIDS

A high frequency signal is transmitted with a very narrow beam angle with two-wire technology. The signal is reflected by the bulk material and received back to the sensor. The frequency difference, which is directly proportional to the distance, is then further processed and output as the level signal. Thanks to the high degree of protection for bulk solids applications, the sensor is ideal across all industries. Installation is also possible outdoors on free-standing stockpiles.

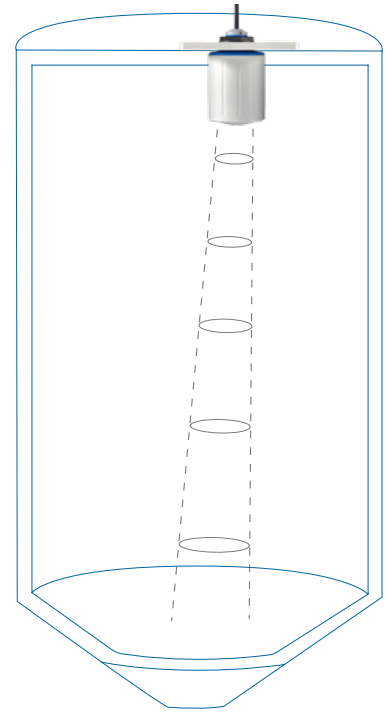

NR 4100
Mounting
thread
Measuring
range
up to 30 m



NR 4100
Mounting
flange
Measuring
range
up to 30 m



UWT LevelApp

SPECIAL FEATURES:

- Compact with 1" connection thread (PVDF)
- Measurement up to the antenna tip (minimal blocking distance)
- High sensitivity (DK value ≥ 1.1)
- 80 GHz technology
- 4° narrow beam angle
- Potted PVDF housing, ingress protection IP66/ IP68
- Temperature range -40 °C to +80 °C
- Quick-Start Wizard
- Configuration via UWT LevelApp
- WHG certification

OUR SOLUTIONS FOR:

- Lightest and heavy bulk goods
- Dusty environments
- Condensation and strong caking
- Narrow, medium-sized silos up to 30 m
- Optimum reflections of bulk material with material cone
- Aggressive materials
- Potentially explosive areas
- Individual positioning of the sensor

NivoRadar®



RADAR SENSOR FOR LIQUIDS

A high frequency signal is transmitted with a very narrow beam angle. The signal is reflected by the medium and received back to the sensor. The frequency difference, which is directly proportional to the distance, is then further processed and output as the level signal. The sensor is ideal for use in water treatment tanks and, due to its design, is also suitable for acids and alkalis. It is possible for measurement to be made through the tank top of plastic containers.

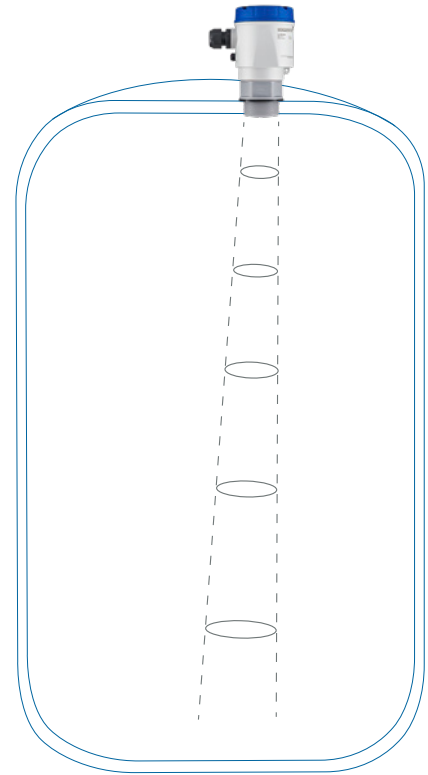

NR 7100
Without Display
Measuring range up to 10 m

NR 7200
With Display
Measuring range up to 20 m

NR 7200
Plug on Display



UWT LevelApp
Wireless sensor setting



Google Play



App Store

SPECIAL FEATURES:

- Very compact with 1 ½" connection thread (PVDF)
- Measurement up to the antenna tip (no blocking distance)
- High sensitivity (DK value ≥ 1.1)
- 80 GHz technology
- 8° narrow beam angle
- Potted electronics, ingress protection IP66/ IP67
- Temperature range -40 °C to +80 °C
- Quick-Start Wizard
- Configuration via UWT LevelApp
- WHG certification

OUR SOLUTIONS FOR:

- Highly viscous liquids
- Very strong caking
- Steam, outgassing and condensation
- Optimal reflection of moving surfaces
- Aggressive materials
- Potentially explosive areas
- Individual positioning of the sensor

NivoGuide®



TDR GUIDED WAVE RADAR SENSOR FOR SOLIDS

High-frequency microwave pulses are coupled to a cable or rod and guided along the probe. The emitted pulse is reflected by the product surface. The time difference between the transmitted and reflected pulse is converted to a level.

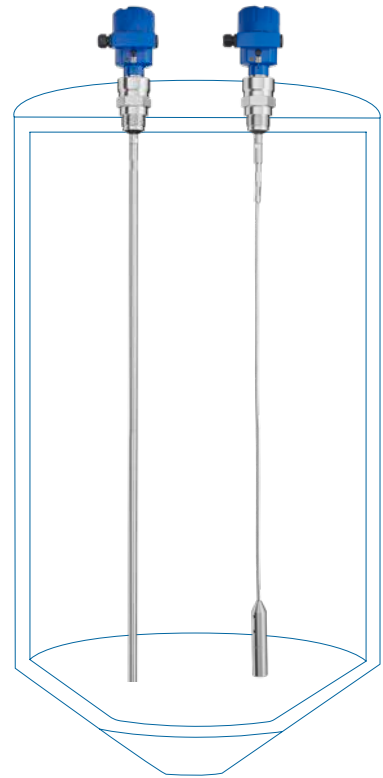

NG 3100 Rod



NG 3100 Rope



Programming module



Lid with viewing window



Pluggable display and adjustment module

SPECIAL FEATURES:

- Adjustable probes (up to 75 m)
- Very high sensitivity ($DK \geq 1.5$)
- PA-coated rope probe
- Temperature range - 40 °C up to +200 °C
- Pressure-resistant versions up to 40 bar
- Robust design
- Various electronics versions (4..20 mA / HART, Modbus)
- Configuration via UWT LevelApp

OUR SOLUTIONS FOR:

- Bulk materials with strong withdrawal forces
- Strong caking
- Abrasive materials
- Dusty environment
- Explosive environments

NivoGuide®



TDR GUIDED WAVE RADAR SENSOR FOR LIQUIDS & INTERFACE

High-frequency microwave pulses are coupled to a cable or rod and guided along the probe. The emitted pulse is reflected by the product surface. The time difference between the transmitted and reflected pulse is converted to a level.

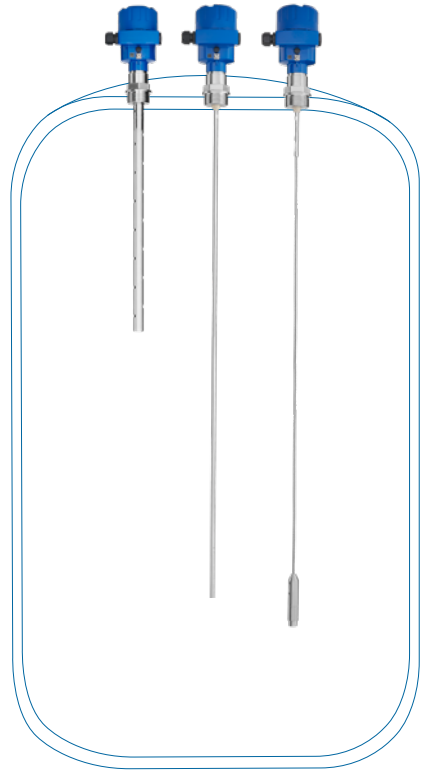

NG 8100 Rod



NG 8100 Rope



NG 8100 Coax



NG 8200 Rod



NG 8200 Coax



NG 8200 Rope



SPECIAL FEATURES:

- Adjustable probes (up to 75 m)
- Very high sensitivity ($DK \geq 1.4$)
- Temperature solutions -196 °C to $+450\text{ °C}$
- For extremely high pressure up to 400 bar
- Second line of defense (optional)
- Minimal blocking distance
- Boiler approval
- Various electronics versions (4..20 mA / HART, Modbus)
- Additional power supply
- Configuration via UWT LevelApp

OUR SOLUTIONS FOR:

- Liquids with moving surface
- Strong caking
- Small containers with fixtures
- Condensation and foam generation, steam
- High hygiene requirements
- Explosive environments
- Interface measurement

NivoTec®

LEVEL MONITORING AND VISUALISATION

Various technologies are available for level indication, which can be configured project-specifically. Simple LED digital displays for the evaluation of a 4-20 mA signal for installation in control cabinets or for wall mounting as well as touch panels and web server modules with visualisation software. The web server solutions meet all the requirements of modern level monitoring.

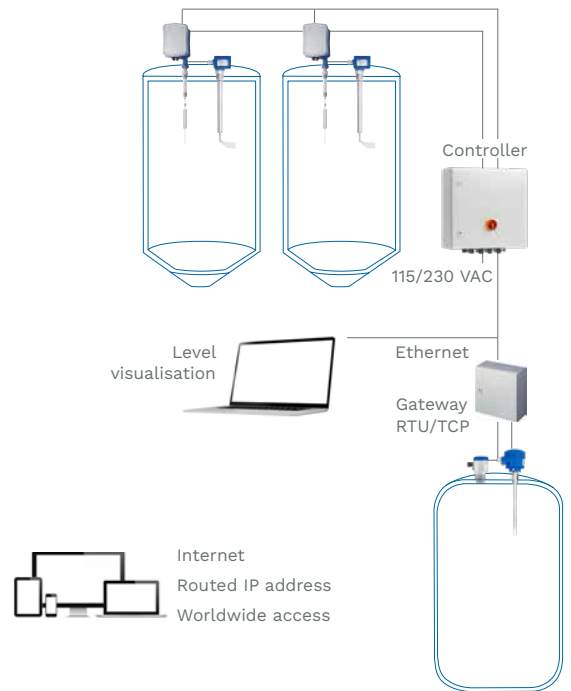

NT 3500
Level
visualisation
from a PC via
webserver



NT 4500
Standardised
level
visualisation



NT 4600
Level
visualisation
via 7" touch
panel



NT 4700
Level
indicator with
digital display



NT 4900
Level
indicator with
digital display



NT 9000
Local fill level
display with
LC-Display



SPECIAL FEATURES:

- Autonomous system without expensive licenses
- Access via standard browser software
- Transmits levels into the Ethernet, make them transparent and evaluable
- Evaluation of level signal via Modbus RTU, ethernet TCP, 4-20mA any sensor technology or counting pulse
- Worldwide access via remote data query
- Data storage and download with trend query via software
- Individually configurable

OUR SOLUTIONS FOR:

- Complete systems for optimized silo/tank management
- Reasonably priced compact systems
- Monitoring up to 50 containers
- Display of levels in weight, height, percent, volume, etc. (programmable)



NivoLED®

SIGNAL LAMP FOR HAZARDOUS AREAS

A control light designed for use in explosive environments, featuring two-colour switching and 360° visibility. Its high brightness is visible even from a great distance, ensuring comprehensive safety.

SPECIAL FEATURES:

- M20 x 1.5 or NPT ½" connection thread
- Two-colour shifting (red, green)
- 360° visibility
- High brightness
- Long service life
- Low power consumption
- Various connection voltages
- Housing material PVDF
- Ambient temperature -40 °C to +60 °C
- Protection class IP 68, NEMA Type 4X
- Approvals for ATEX, IEC-Ex, cFMus

NL 9000
LED Signal lamp



OUR SOLUTIONS FOR:

- Gas and dust explosion hazardous areas
- Attachment to level measuring devices, control cabinets, and process systems



Application
data sheet

UWT SENSORS FOR DEMANDING MEASUREMENT TASKS

Benefit from our experience and you will find a suitable product for all types of application

PRODUCT MATRIX SOLIDS		LEVEL LIMIT MEASUREMENT						CONTINUOUS MEASUREMENT				
Product	Rotonivo® RN 3/4/6	Vibranivo® VN 1/2/4/5/6	Mononivo® MN 4	RFnivo® RF 3	Capanivo® CN 4	NivoBob® NB 3	NivoBob® NB 4	NivoRadar® NR 3	NivoRadar® NR 4	NivoGuide® NG 3		
Measuring principle	Rotation	Vibration	Vibration	Capacitive	Capacitive	Lot System	Lot System	Radar	Radar	Guided Radar (TDR)		
Granulate / powder	✓	✓	✓	✓	✓	✓	✓	✓	✓	✓		
Solids in liquid	-	✓	-	-	-	✓	-	-	-	-		
Material prone to caking	✓	-	-	✓	●	✓	✓	●	●	●		
Abrasive material	✓	✓	✓	●	-	✓	✓	✓	✓	●		
Sensitivity (bulk density / DK)	≥ 15 g/L	< 5 g/L **	≥ 20 g/L	DK ≥ 1.5	DK ≥ 1,6	≥ 20 g/L	≥ 20 g/L	DK ≥ 1.6	DK ≥ 1.1	DK ≥ 1.5		
Process temperature	-40...1100 °C	-40...150 °C	-40...150 °C	-40...500 °C	-40...180 °C	-40...250 °C	-40...80 °C	-40...200 °C	-40...80 °C	-40...200 °C		
Process pressure	10 bar	16 bar	16 bar	25 bar	25 bar	1,7 bar	0.2 bar	3 bar	3 bar	40 bar		
High mechanical load	✓	●	●	✓	-	●	●	●	✓	●		
High humidity	✓	-	-	✓	✓	✓	✓	●	✓	●		
Vibration in process	●	✓	●	✓	●	●	●	✓	✓	●		
EHEDG	●	-	-	✓	-	-	-	-	-	-		
SIL	✓	-	-	-	-	-	-	-	-	✓		
EX certification	✓	✓	✓	✓	✓	✓	✓	✓	✓	✓		
Sensor material	316L	316L	316L	316L / PPS Ceramic	PPS	304/303/316	Al/303/316	316L/PEEK	PVDF	316L/PEEK		

Certification*

PRODUCT MATRIX LIQUIDS		LEVEL LIMIT MEASUREMENT					CONTINUOUS MEASUREMENT				
Product	Vibranivo® VN 7	Capanivo® CN 7	Capanivo® CN 8	RFnivo® RF 8	NivoBob® NB 3	NivoCapa® NC 8	NivoRadar® NR 7	NivoRadar® NR 8	NivoGuide® NG 8		
Measuring principle	Vibration	Capacitive	Capacitive	Capacitive	Lot System	Capacitive	Radar	Radar	Guided Radar (TDR)		
Material properties	Waterbased	✓	✓	✓	✓	✓	✓	✓	✓		
	Oil / viscose media	✓	✓	✓	✓	✓	✓	●	✓		
Material prone to caking	Foam	✓	✓	✓	✓	✓	✓	●	✓		
	Material prone to caking	✓	✓	✓	✓	✓	✓	●	●		
Interface	Interface	●	✓	✓	✓	✓	✓	-	-		
	Sensitivity (Medium density / DK)	≥ 0,5 g/cm³	DK ≥ 1.5	DK ≥ 1.5	DK ≥ 1.5	DK ≥ 1.5	DK ≥ 1.5	DK ≥ 1.1	DK ≥ 1.1	DK ≥ 1.4	
Process conditions	Process temperature	-40...150 °C (CIP / SIP ...150 °C)	-40...125 °C (CIP / SIP ...150 °C)	-40...125 °C	-40...400 °C	-40...200 °C	-40...80 °C	-196...450 °C	-196...450 °C	-196...450 °C	
	Process pressure	40 bar	25 bar	25 bar	35 bar	35 bar	3 bar	160 bar	400 bar		
High mechanical load	High mechanical load	●	●	●	●	●	✓	✓	●		
	Immersion length (max.)	4 m	20 m	30 m	25 m	50 m	0 m	0 m	75 m		
Vibration in process	Vibration in process	✓	✓	●	✓	✓	●	●	●		
	Moving surface	✓	●	✓	✓	✓	✓	✓	✓		
EHEDG	EHEDG	✓	✓	-	-	-	-	✓	-		
	SIL	-	-	✓	-	-	-	✓	✓		
Lloyd's Register	Lloyd's Register	-	✓	✓	✓	-	-	-	-		
	EX certification	-	✓	✓	✓	✓	✓	✓	✓		
Wetted parts	Stainless steel (1.4404)	316L/PPS/PVDF/PEEK	316L/PPS/PVDF	316L/PFA/PEEK/Ceramic	301/303/PA/PP	316L/PFA/PEEK	PVDF	316L/PTFE/PEEK/PP/Ceramic	316L/PEEK/Ceramic		
	Wetted parts	316L/PPS/PVDF/PEEK	316L/PPS/PVDF	316L/PFA/PEEK/Ceramic	301/303/PA/PP	316L/PFA/PEEK	PVDF	316L/PTFE/PEEK/PP/Ceramic	316L/PEEK/Ceramic		

* further certificates available on request

** capable of measuring the lightest of material lower than 5 g/l

We reserve the right to make changes. The terms and conditions apply (www.uwtgroup.com).

✓ perfect choice

● can be used (details to be clarified)

- not recommended

GLOBAL PARTNER

As an expert in level measurement technology, UWT is the reliable, global solution provider for the simple, safe and accurate detection of levels and limit levels across a wide variety of industries and applications.



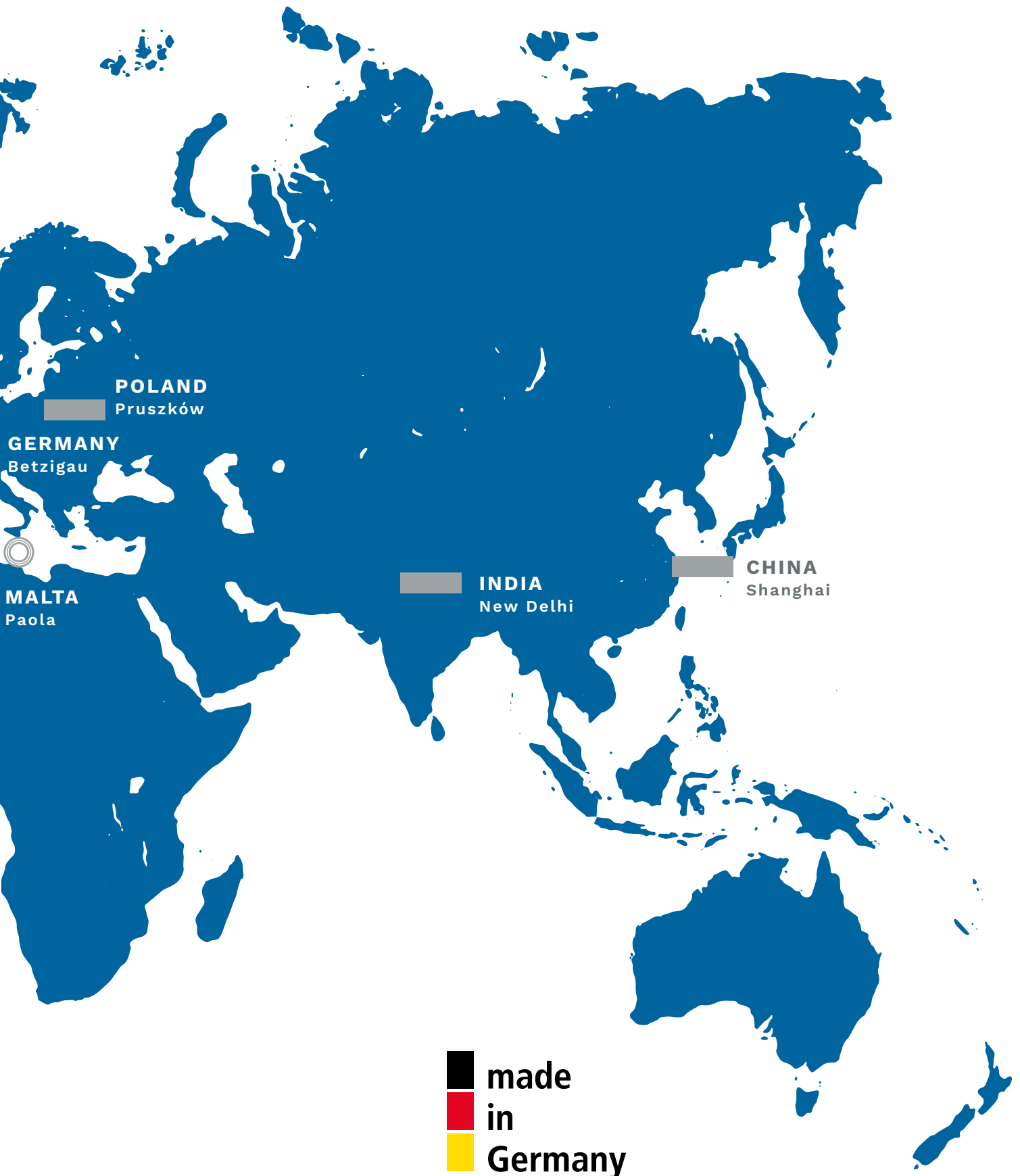

Distribution network
> 90 countries



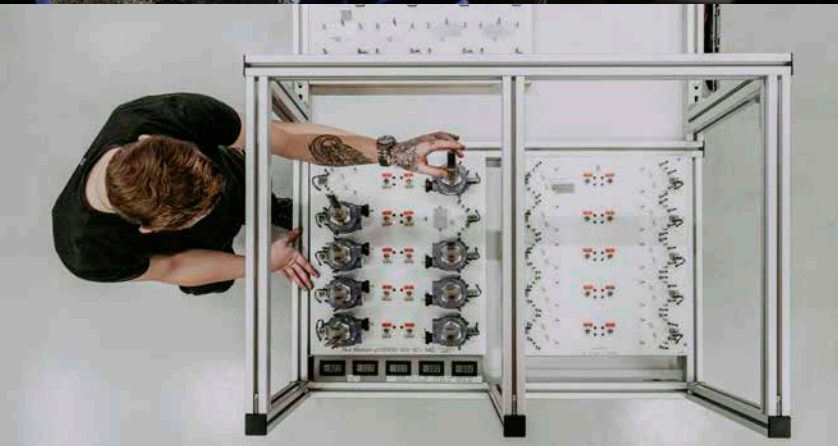
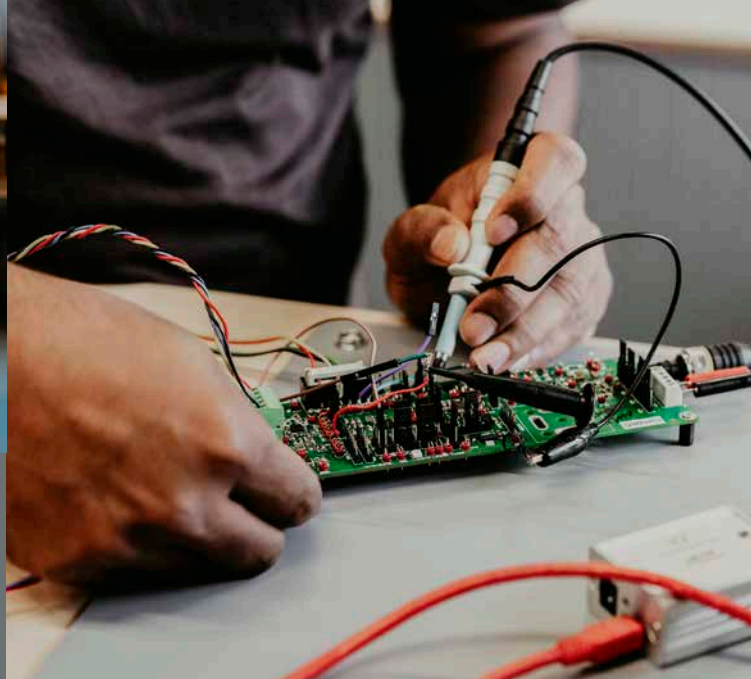

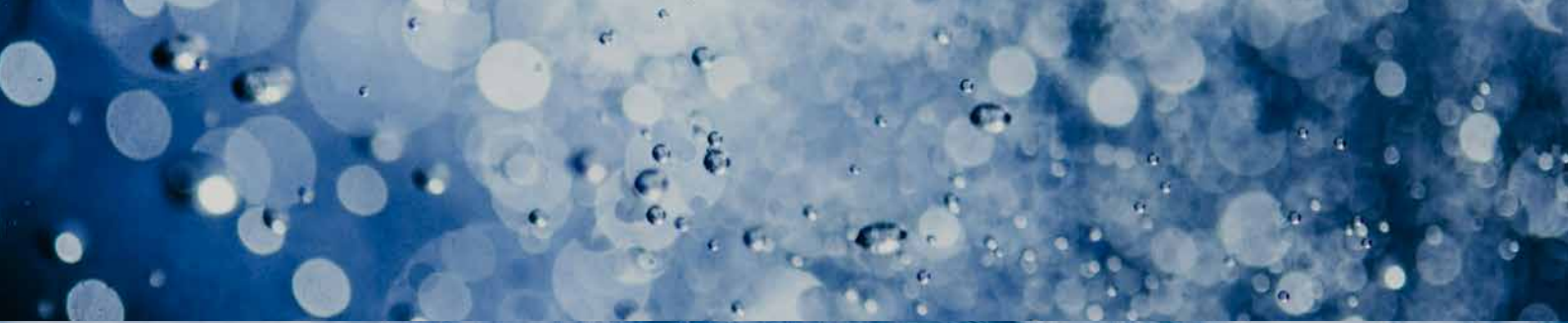

UWT (UK) Ltd
20 Main Road, Dorrington | Shrewsbury SY5 7JW | Shropshire, UK
Tel +44 1743 718883 | info.uk@uwtgroup.com



uwtgroup.com

Westendstr. 5 | 87488 Betzigau | Germany
Tel +49 831 57123-0 | info@uwtgroup.com